

1 RoHS

2 本产品符合我司QA-3-04-005
环境管理物质标准规范

3 包装图

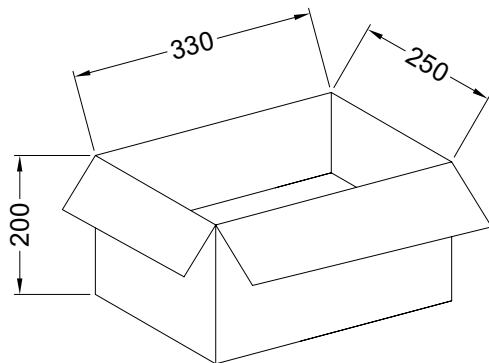
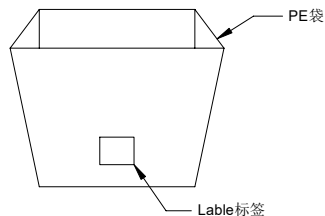
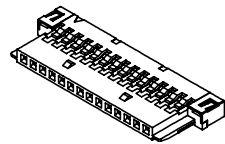

胶带ADHESIVE TAPE

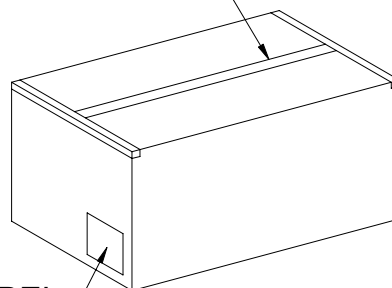

Note注解:

1. Put Housing in a PE bag, PE bag gauge for: 130 * 135 * 0.10 mm, Packing detail see the table below

将 Housing放入PE袋内, PE袋规为:130*135*0.10mm,详细包装见下表

2. Put PE bag packed products in specifications of 330 * 250 * 300 mm cartons, Packing detail see the table below

将装好产品的PE袋放入规格为330*250*200mm的纸箱内, 详细包装见下表

3. Label depends on customer request, carton opening joint with transparent tape
标签依客户要求而定, 纸箱开口处用透明胶带贴合.

Poles	Bag PCS	CARTON Bag	CARTON PCS
08	1000	75	75K
20	1000	75	75K
30	1000	75	75K

A

2020/05/18	B		Update Drawing Frame	Xue	Robing
日期	版次	变更编号	变更内容说明	变更人	核准

一般公差
.X ±0.30
.XX ±0.20
.XXX ±0.10
X° ±0.2°
视角

东莞市翰皓精密电子有限公司 DONGUAN HANHAO PRECISION ELECTRONIC CO.,LTD			
核准	审查	制作	日期
		Allen	2013/08/31

料号: 1008H-XX-XX				
名称: 1.00mm Housing Package				
单位	比例	页次	版本	供应商编号
mm	1:1	1/1	B	XXXX

A

1 2 3 4 5 6 7 8

RoHS

本产品符合我司QA-3-04-005
环境管理物质标准规范

包装图

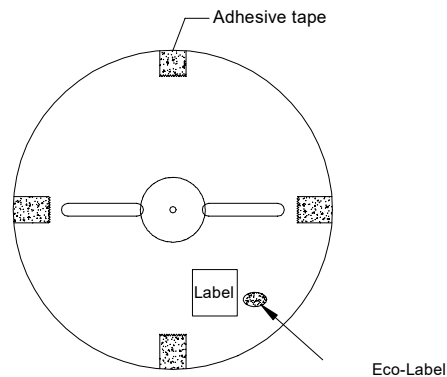

Note注解:

1.Quantity数量:

20K PCS/REEL 一卷20K/PCS

14 REEL/BOX 一箱14卷

280K PCS/BOX 一箱280K/PCS

2.Each reel and outer box must be labeled and
Eco-Label Respectively labeled

每盘和外箱都必须有标签及环保标签分别标示

3.Terminal winding direction as shown

端子缠绕方向如左图所示

4. There shall be no dirt such as deformation phenomenon,
Mantissa box fillers must be used

每箱不可有脏污, 变形现象, 尾数箱必须用填充物

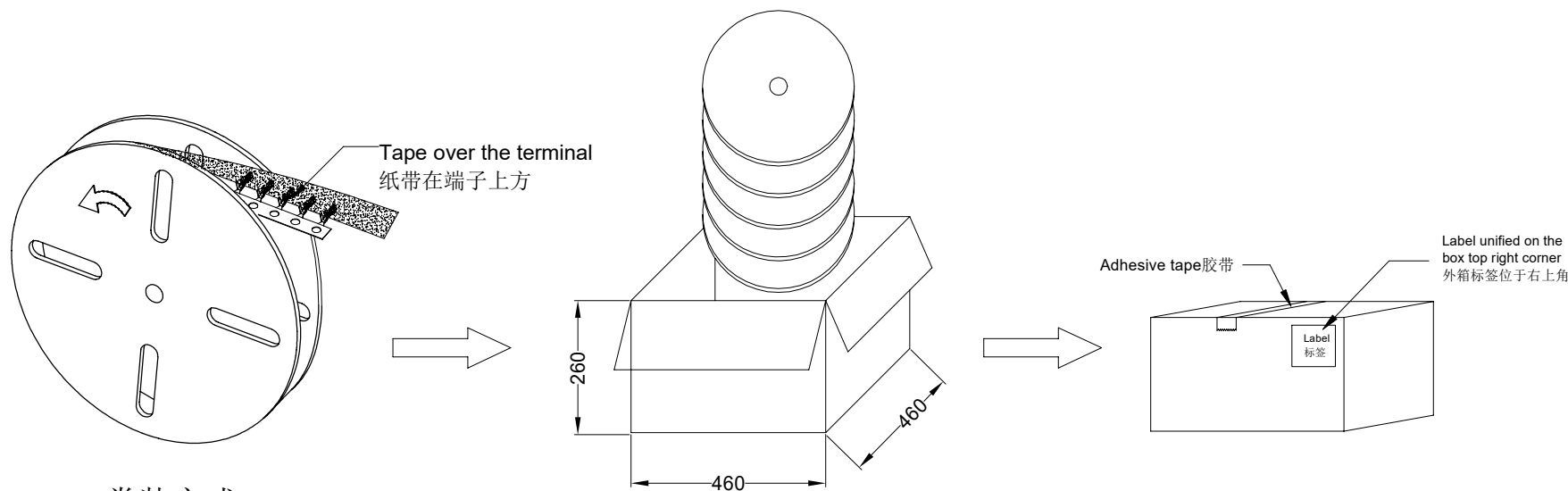

					一般公差 .X ±0.30 .XX ±0.20 .XXX ±0.10 X° ±0.2° 视角				东莞市翰皓精密电子有限公司 DONGUAN HANHAO PRECISION ELECTRONIC CO.,LTD				料号: H1009T 名称: 1.00mm Terminal Packing			
2020/05/18	B		Update Drawing Frame	Xue	Robing	核准	审查	制作	日期	Allen	2013/09/29	单位	比例	页次	版本	供应商编号
日期	版次	变更编号	变更内容说明	变更人	核准							mm	1:1	1/1	B	XXXX

RoHS

本产品符合我司QA-3-04-005
环境管理物质标准规范

包装图

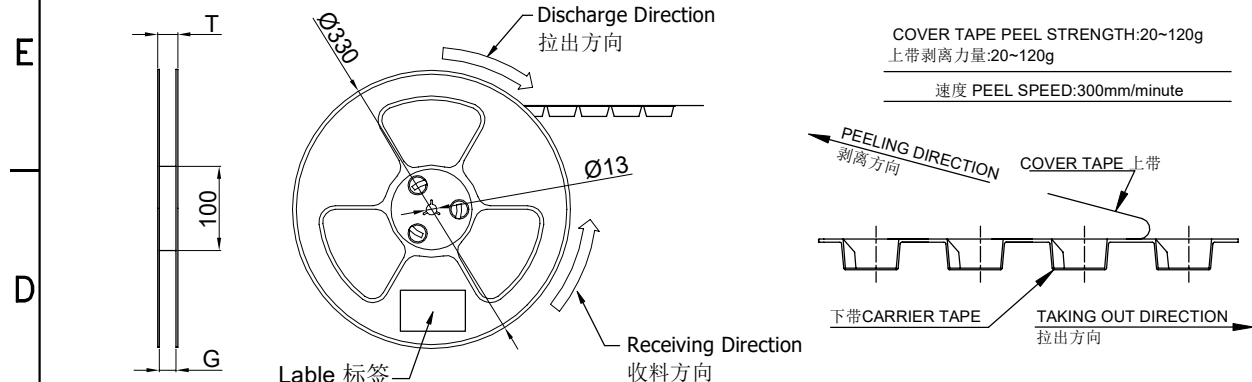
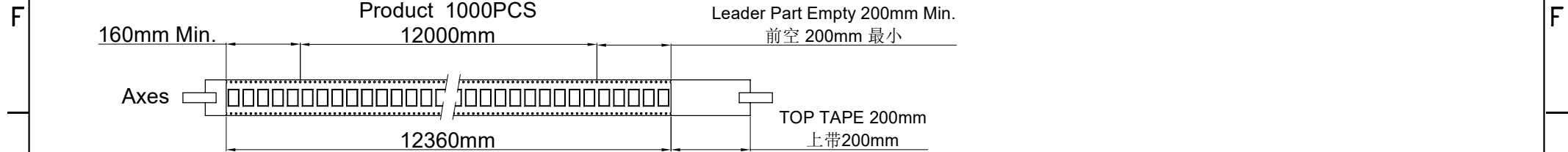

Lable 标签
Single hole: None Hole Side
单孔: 贴无链孔侧
Double hole: Elliptical Hole Side
双孔: 贴椭圆孔侧

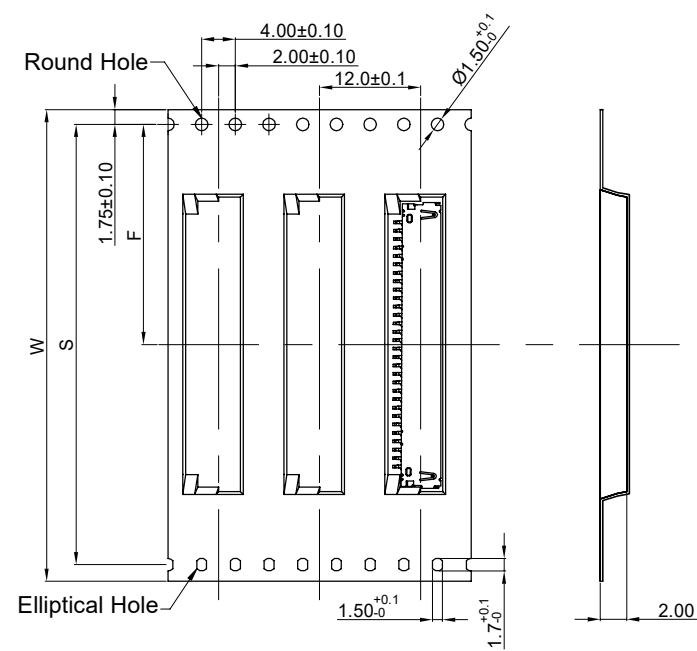
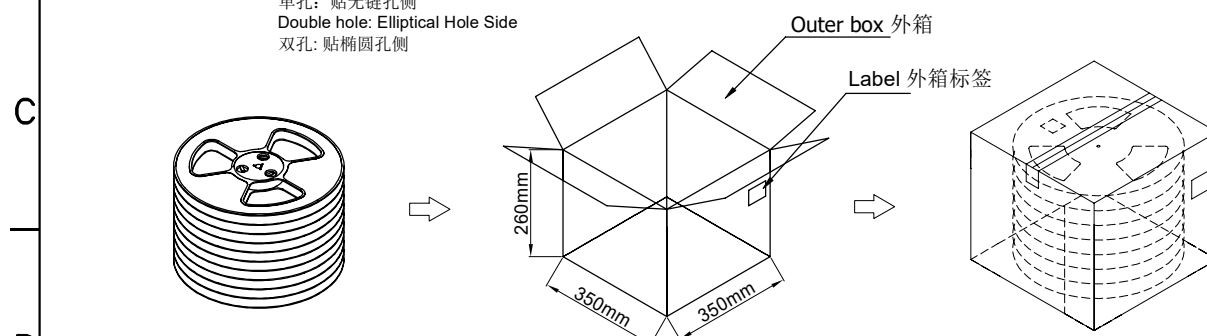

Note:

- Carrier Camber Is Within 1mm In 100mm; 带长100mm内容许弯曲度1mm
- 10 Sprocket Hole Pitch Cumulative Tolerance±0.2MM; 圆孔十个孔距离累计允许公差为±0.2mm
- Carrier tape material for PS; 下带材质为PS材质; Color颜色:Black黑色
- bracer保护带: Color颜色:Natural透明色,厚度0.40mm最小
- Thickness=0.35±0.05; 材料厚度为0.35±0.05mm
- Carton material纸箱材质:K=K; Carton Thickness纸箱厚度: 6±1mm

H1009WRS-XX	Part No.	W	S	F	T (MAX)	G (MAX)	REEL /PCS	CARTON /R	CARTON /PCS
	H1009WRS-30	56	52.4	26.2	61.4	56.40	1000	3R	3K

						<p>东莞市翰皓精密电子有限公司 DONGUAN HANHAO PRECISION ELECTRONIC CO.,LTD</p>				料号: H1009WRS-XX				
						<p>核准 审查 制作 日期</p>				名称: 1.00mm Connectors SMT 90° Package				
2020/05/18	B		Update Drawing Frame	Xue	Robing					单位	比例	页次	版本	供应商编号
日期	版次	变更编号	变更内容说明	变更人	核准	Jova				mm	1:1	1/1	B	XXXX

