

1 RoHS

2 本产品符合我司QA-3-04-005
环境管理物质标准规范

3 包装图

Note注解:

1. Put Housing in a PE bag, Packing detail see the table below
将 Housing放入PE袋内, 详细包装见下表
2. Put PE bag packed products in specifications of 465 * 280 * 290 mm cartons,
Packing detail see the table below
将装好产品的PE袋放入规格为465*280*290mm的纸箱内, 详细包装见下表
3. Label depends on customer request, carton opening joint with transparent tape
标签依客户要求而定, 纸箱开口处用透明胶带贴合.
4. Carton material: K=K, Carton thickness: 6~7mm
纸箱材质:K=K, 纸箱厚度:6~7mm

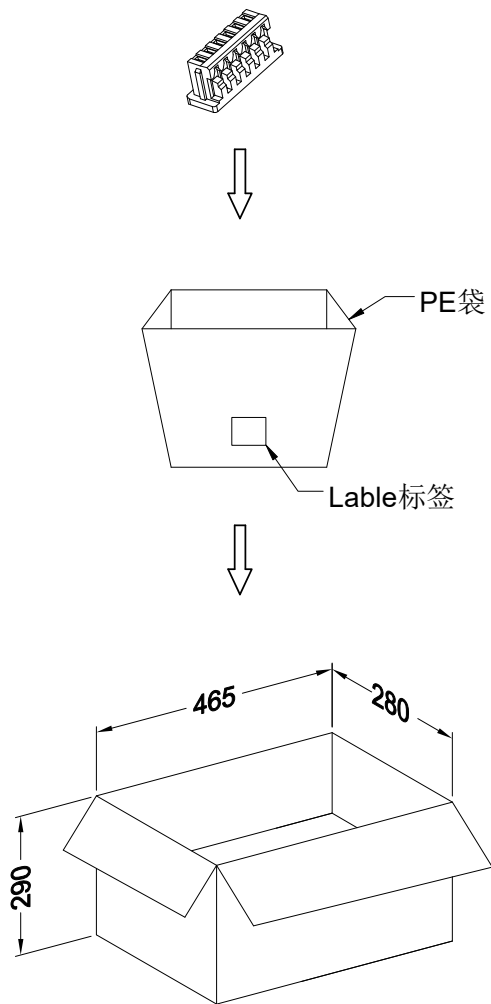

Poles	Bag PCS	CARTON Bag	CARTON PCS
02	2000	200	400K
03	1000	300	300K
04	1000	200	200K
05	1000	150	150K
06	1000	120	120K
07	1000	100	100K
08	1000	100	100K
09	1000	80	80K
10	1000	80	80K
11	1000	60	60K
12	1000	60	60K
13	1000	60	60K
14	1000	60	60K
15	1000	60	60K
16	1000	60	60K

						一般公差		东莞市翰皓精密电子有限公司 DONGUAN HANHAO PRECISION ELECTRONIC CO.,LTD				料号: M1254H-XX													
						.X ±0.35						核准		审查		制作		日期		名称: 1.25mm Housing Packing					
						.XX ±0.25		责能桂		/		杨梅		2013/08/31		单位		比例		页次		版本		编号	
2020/03/26						B		EN20200326001		更新图框		杨梅		责能桂		mm		1:1		1/1		B		A-043	
日期		版次		变更编号		变更内容说明		变更人		核准		视角													

RoHS

本产品符合我司QA-3-04-005
环境管理物质标准规范

包装图

Note注解:

1. Place Housing into PE bag and seal PE bag. Label.
将 Housing放入PE袋内, 并将PE袋封好.贴上标签.
2. Put PE bag packed products in cartons, Packing detail see the table below
将装好产品的PE袋放入纸箱内, 详细包装见下表
3. Label depends on customer request, carton opening joint with transparent tape
标签依客户要求而定, 纸箱开口处用透明胶带贴合.
4. There shall be no dirt such as deformation phenomenon, Mantissa box fillers must be used
每箱不可有脏污, 变形现象, 尾数箱必须用填充物
5. Carton material: K=K, Carton thickness: 6~7mm
纸箱材质:K=K, 纸箱厚度:6~7mm

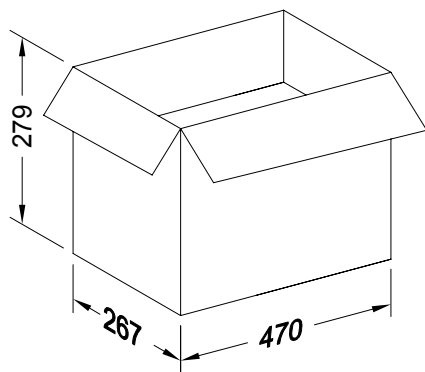
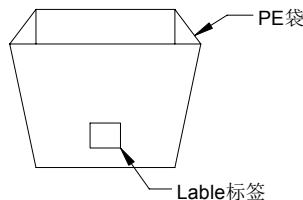

胶带ADHESIVE TAPE

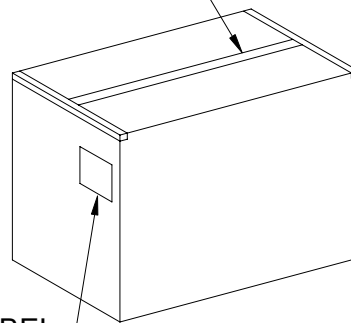

标签LABEL

Poles	Bag PCS	Box PCS
02	1000	150K
03	1000	120K
04	1000	100K
05	1000	100K
06	1000	80K
07	1000	70K
08	1000	60K
09	1000	50K
10	1000	50K

					<p>一般公差</p> <p>.X ±0.35</p> <p>.XX ±0.25</p> <p>.XXX ±0.15</p> <p>X° ±0.2°</p> <p>视角</p>				<p>东莞市翰皓精密电子有限公司</p> <p>DONGGUAN HANHAO PRECISION ELECTRONIC CO.,LTD</p>				<p>料号: M1254MH-XX</p>				
					<p>核准</p> <p>审查</p> <p>制作</p> <p>日期</p>				<p>名称: 1.25mm Housing Packing</p>								
2020/03/26	B	EN20200326001	更新图框	滕敏	贲能桂	贲能桂	秦胜钦	滕敏	2018/06/07	单位	比例	页次	版本	编号			
日期	版次	变更编号	变更内容说明	变更人	核准	贲能桂	秦胜钦	滕敏	2018/06/07	mm	1:1	1/1	B	A-022			

RoHS

本产品符合我司QA-3-04-005
环境管理物质标准规范

包装图

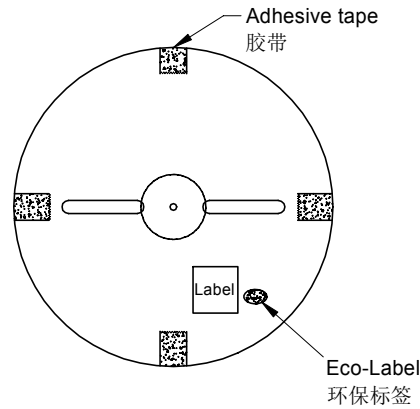

Note注解:

1.Quantity数量:

15K PCS/REEL 一卷15K/PCS

10 REEL/BOX 一箱10卷

150K PCS/BOX 一箱150K/PCS

2.Each reel and outer box must be labeled and Eco-Label Respectively labeled

每盘和外箱都必须有标签及环保标签分别标示

3.Terminal winding direction as shown

端子缠绕方向如左图所示

4. There shall be no dirt such as deformation phenomenon, Mantissa box fillers must be used

每箱不可有脏污, 变形现象, 尾数箱必须用填充物

5. Carton material: K=K, Carton thickness: 6~7mm

纸箱材质:K=K, 纸箱厚度: 6~7mm

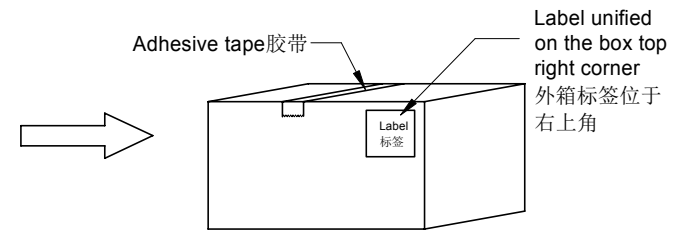
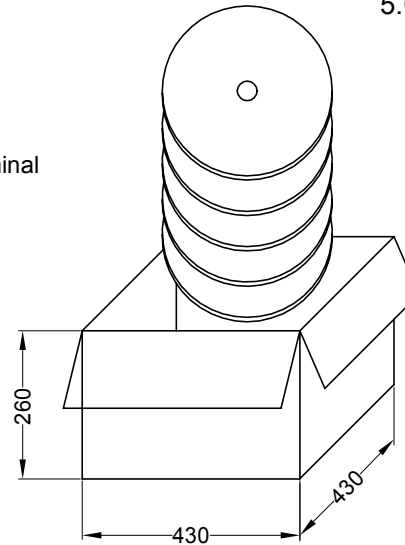
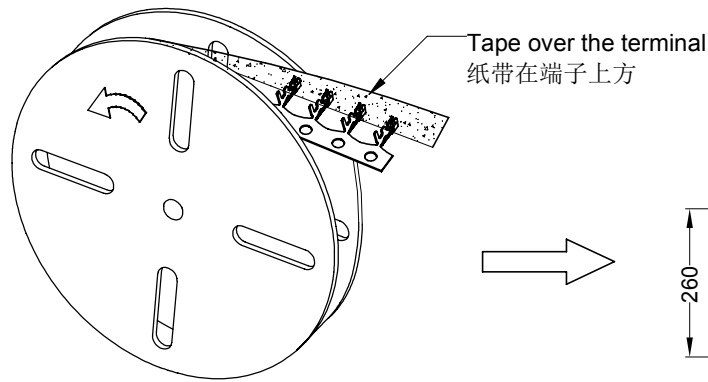

卷装方式
Package way

						<p>一般公差</p> <p>.X ±0.35</p> <p>.XX ±0.25</p> <p>.XXX ±0.15</p> <p>X° ±0.2°</p> <p>视角</p>				<p>东莞市翰皓精密电子有限公司</p> <p>DONGGUAN HANHAO PRECISION ELECTRONIC CO.,LTD</p>				<p>料号: M1254T</p>				
						<p>核准</p> <p>审查</p> <p>制作</p> <p>日期</p>				<p>名称:</p> <p>1.25mm Terminal Packing</p>								
2020/03/26	B	EN20200326001	更新图框	秦胜钦	贲能桂	贲能桂	/	秦胜钦	2013/09/29	单位	比例	页次	版本	编号				
日期	版次	变更编号	变更内容说明	变更人	核准	贲能桂	/	秦胜钦	2013/09/29	mm	1:1	1/1	B	A-022				

RoHS

本产品符合我司QA-3-04-005
环境管理物质标准规范

包装图

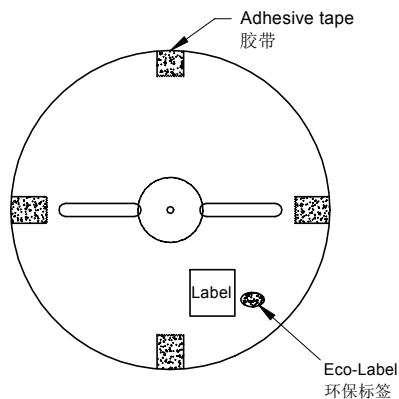

Note注解:

1.Quantity数量:

15K PCS/REEL 一卷15K/PCS

11 REEL/BOX 一箱11卷

165K PCS/BOX 一箱165K/PCS

2.Each reel and outer box must be labeled and Eco-Label Respectively labeled

每盘和外箱都必须有标签及环保标签分别标示

3.Terminal winding direction as shown

端子缠绕方向如左图所示

4. There shall be no dirt such as deformation phenomenon, Mantissa box fillers must be used

每箱不可有脏污, 变形现象, 尾数箱必须用填充物

5. Carton material: K=K, Carton thickness: 6~7mm

纸箱材质:K=K, 纸箱厚度:6~7mm

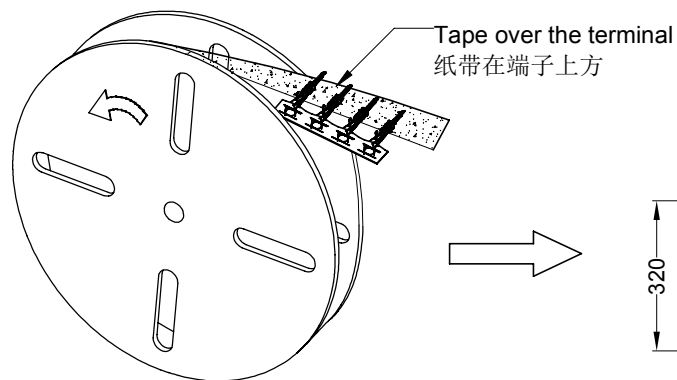

卷装方式
Package way

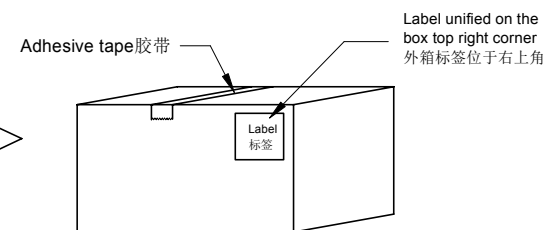
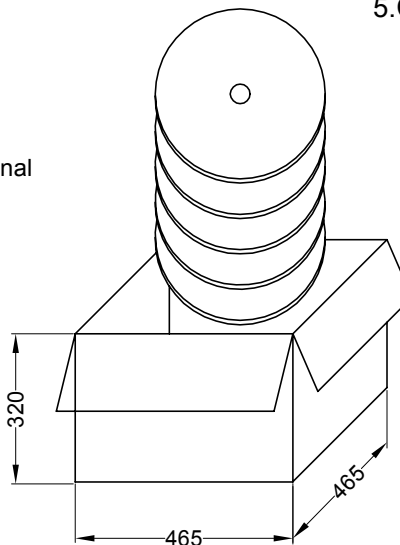

						<p>一般公差</p> <p>.X ±0.35</p> <p>.XX ±0.25</p> <p>.XXX ±0.15</p> <p>X° ±0.2°</p> <p>视角</p>				<p>东莞市翰皓精密电子有限公司</p> <p>DONGGUAN HANHAO PRECISION ELECTRONIC CO.,LTD</p>				<p>料号: M1254FT</p>				
						<p>核准</p> <p>审查</p> <p>制作</p> <p>日期</p>				<p>名称:</p> <p>1.25mm Terminal Packing</p>								
2020/03/26	B	EN20200326001	更新图框	秦胜钦	贡能桂	<p>核准</p> <p>审查</p> <p>制作</p> <p>日期</p>				<p>单位</p> <p>比例</p> <p>页次</p> <p>版本</p> <p>编号</p>								
日期	版次	变更编号	变更内容说明	变更人	核准	<p>贡能桂</p> <p>/</p> <p>秦胜钦</p> <p>2013/08/31</p>				<p>mm</p> <p>1:1</p> <p>1/1</p> <p>B</p> <p>A-022</p>								

RoHS

本产品符合我司QA-3-04-005
环境管理物质标准规范

包装图

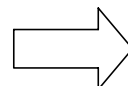
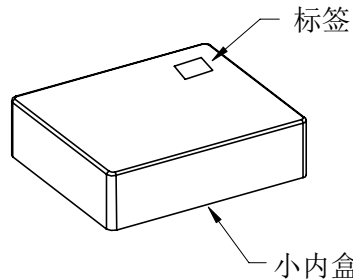
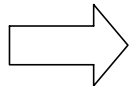
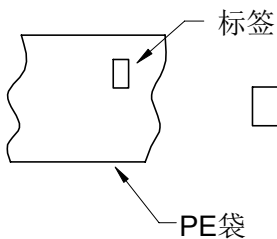
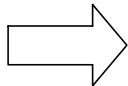
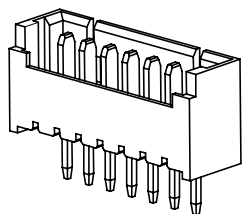

规格: L200*W152*H78mm

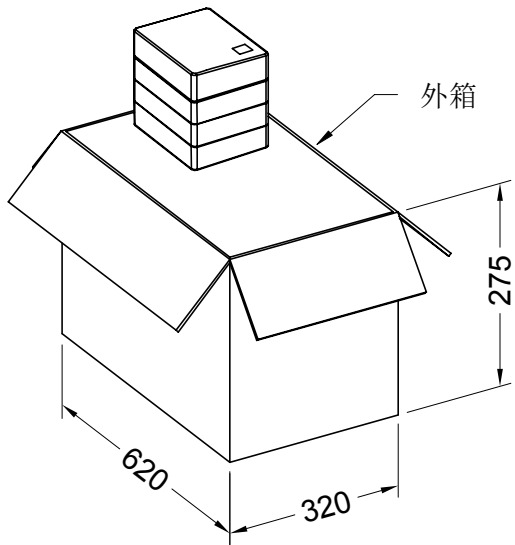

用透明胶带
将纸箱封好

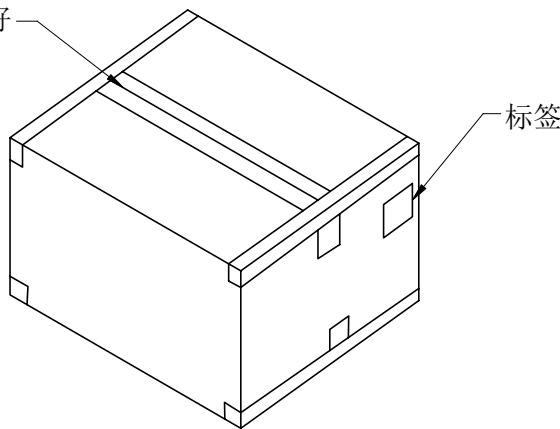
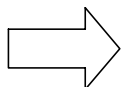

包装说明:

1. 将检验好的产品依包装数量装入PE袋中,同时放入一包干燥剂,并贴好标签。
 2. 将装好产品的PE袋,依包装数量放入小内盒中,并在小内盒上贴上标签。
 3. 将装好的小内盒放入外箱中(一大箱装18盒小内盒)
 4. 用透明胶把外箱四周封好,贴上外箱标签。
- 注: 尾数可用填充物填充。
5. 外箱材质: K=K; 纸箱厚度: 6~7mm

Pin位	袋/PCS	盒/PCS	箱/盒	箱/PCS	
02	2000	16K	18	288K	
03		12K		216K	
04		8K		144K	
05		8K		144K	
06	1000	6K		108K	
07		5K		90K	
08		5K		90K	
09		4K		72K	
10		4K		4K	72K

2020/03/26	B	EN20200326001	更新图框	秦胜钦	贲能桂
日期	版次	变更编号	变更内容说明	变更人	核准

一般公差
.X ±0.35
.XX ±0.25
.XXX ±0.15
X° ±0.2°
视角

东莞市翰皓精密电子有限公司			
DONGGUAN HANHAO PRECISION ELECTRONIC CO.,LTD			
核准	审查	制作	日期
贲能桂	/	杨梅	2019/06/05

料号: M1254W-XX				
名称: 1.25mm Dip 180° Packing				
单位	比例	页次	版本	编号
mm	1:1	1/1	B	A-084

RoHS

本产品符合我司QA-3-04-005
环境管理物质标准规范

包装图

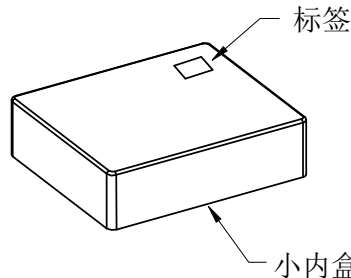
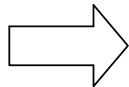
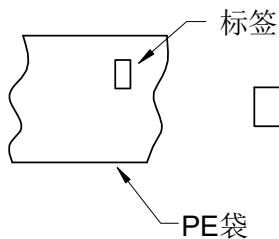
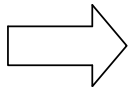
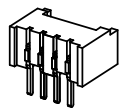

规格: L200*W152*H78mm

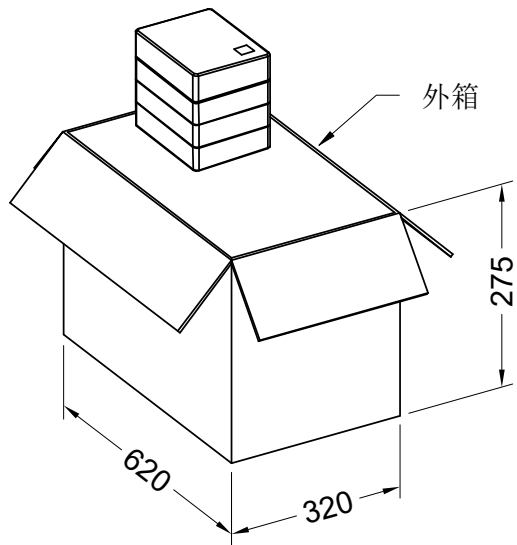

用透明胶带
将纸箱封好

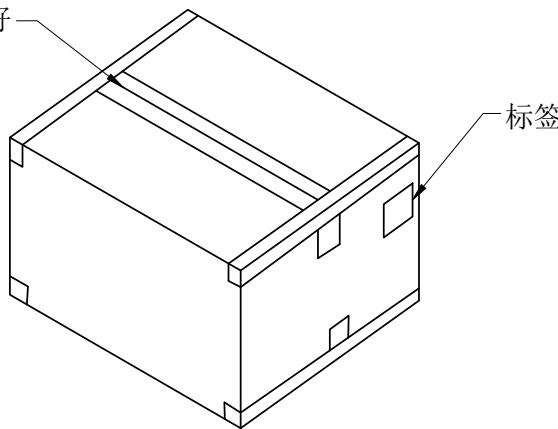
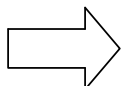

包装说明:

- 1.将检验好的产品依包装数量装入PE袋中,同时放入一包干燥剂,并贴好标签。
 - 2.将装好产品的PE袋,依包装数量放入小内盒中,并在小内盒上贴上标签。
 - 3.将装好的小内盒放入外箱中(一大箱装18盒小内盒)
 - 4.用透明胶把外箱四周封好,贴上外箱标签。
- 注:尾数可用填充物填充。
- 5.外箱材质:K=K;纸箱厚度:6~7mm

Pin位	袋/PCS	盒/PCS	箱/盒	箱/PCS
02	1000	16K	18	288K
03		12K		216K
04		8K		144K
05		8K		144K
06		6K		108K
07		5K		90K
08		5K		90K
09		4K		72K
10		4K		72K

一般公差

.X ±0.35

.XX ±0.25

.XXX ±0.15

X° ±0.2°

视角



东莞市翰皓精密电子有限公司

DONGUAN HANHAO PRECISION ELECTRONIC CO.,LTD

料号: M1254WR-XX

名称: 1.25mm Dip 90° Packing

核准 审查 制作 日期

责能桂 / 杨梅 2019/06/05

单位	比例	页次	版本	编号
mm	1:1	1/1	A	A-084

日期	版次	变更编号	变更内容说明	变更人	核准
----	----	------	--------	-----	----

RoHS

本产品符合我司QA-3-04-005
环境管理物质标准规范

包装图

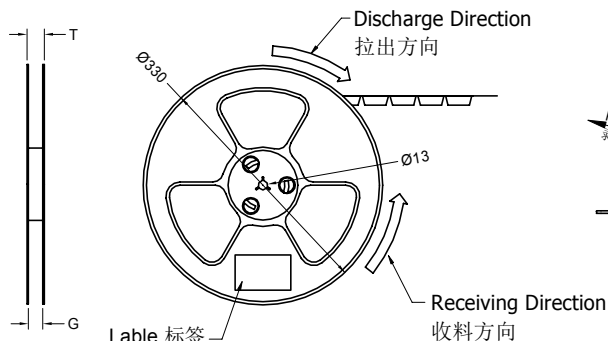
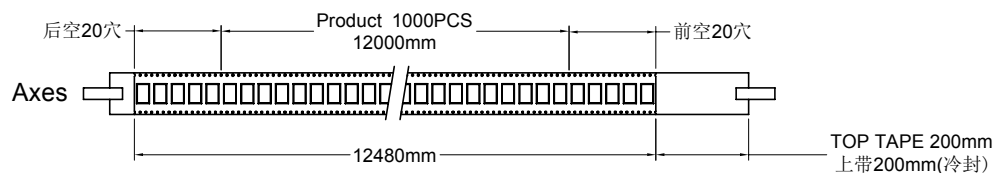

COVER TAPE PEEL STRENGTH:20~120g
剥离力量20~120g
速度 PEEL SPEED:300mm/minute

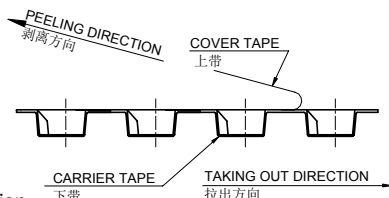

Single hole: None Hole Side
单孔: 贴无链孔侧
Double hole: Elliptical Hole Side
双孔: 贴椭圆孔侧

Waterproof bag
防水袋
Drier
干燥剂放两包10g

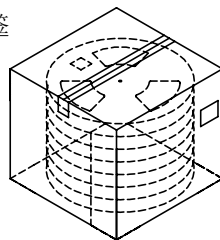
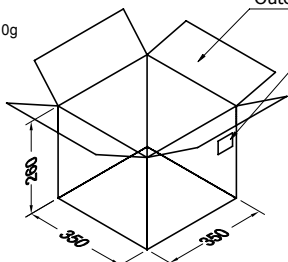
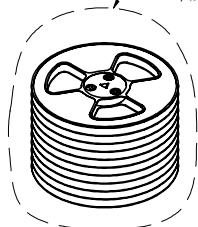

Note:

- Carrier Camber Is Within 1mm In 100mm; 带长100mm内容许弯曲度1mm
- 10 Sprocket Hole Pitch Cumulative Tolerance±0.2MM; 圆孔十个孔距离累计允许公差为±0.2mm
- Carrier tape material for PS; 下带材质为PS材质; Color颜色:Natural透明色
- bracer保护带: Color颜色:Natural透明色, 厚度0.40mm最小
- Thickness=0.40±0.05; 材料厚度为0.40±0.05mm
- Carton material纸箱材质:K=K; Carton Thickness纸箱厚度: 6~7mm

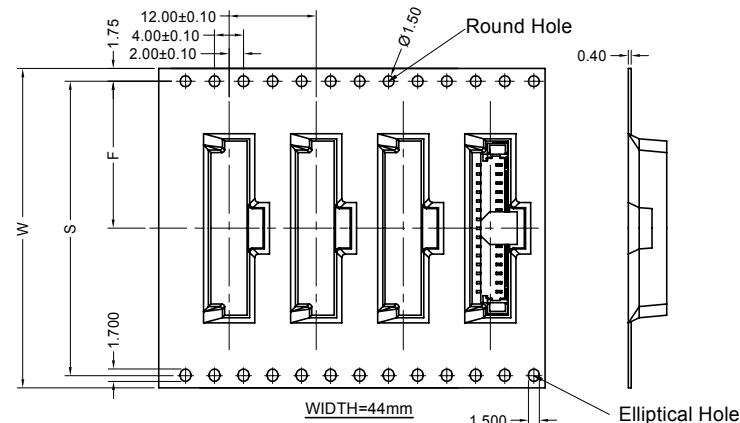
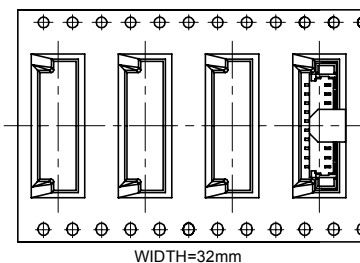
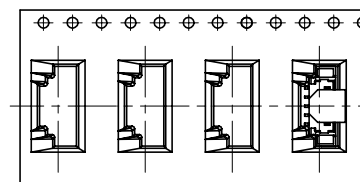

	Pin No.	W	S	F	T	G	REEL /PCS	CARTON /R	CARTON /PCS
M1254WS-XX	M1254WS-02	16	/	7.50	20.50	16.50	1000	11R	11000
	M1254WS-03								
	M1254WS-04	24	/	11.50	28.50	24.50	1000	8R	8000
	M1254WS-05								
	M1254WS-06								
	M1254WS-10	32	28.40	14.20	36.50	32.50	1000	6R	6000
M1254WS-15	44	40.40	20.20	48.50	44.50	1000	5R	5000	

东莞市翰皓精密电子有限公司

DONGGUAN HANHAO PRECISION ELECTRONIC CO.,LTD

料号: M1254WS-XX

名称:

1.25mm SMT 180° Packing

核准 审查 制作 日期

2019/11/20

单位	比例	页次	版本	编号
mm	1:1	1/1	B	A-007

日期	版次	变更编号	变更内容说明	变更人	核准
2020/03/26	B	EN20200326001	更新图框	秦胜钦	贡能桂

一般公差	
.X	±0.35
.XX	±0.25
.XXX	±0.15
X°	±0.2°
视角	

核准 审查 制作 日期

2019/11/20

单位	比例	页次	版本	编号
mm	1:1	1/1	B	A-007

RoHS

本产品符合我司QA-3-04-005
环境管理物质标准规范

包装图

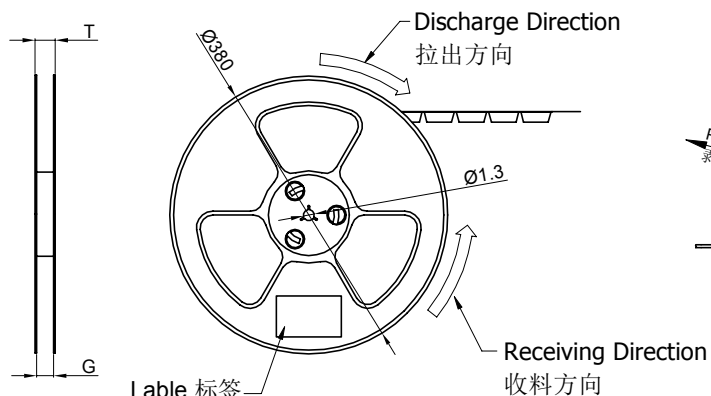
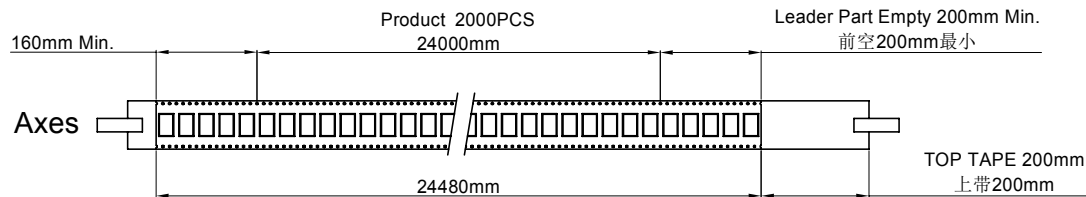

Lable 标签
Single hole: None Hole Side
单孔: 贴无链孔侧
Double hole: Elliptical Hole Side
双孔: 贴椭圆孔侧

COVER TAPE PEEL STRENGTH:20~120g
剥离力量20~120g
速度 PEEL SPEED:300mm/minute

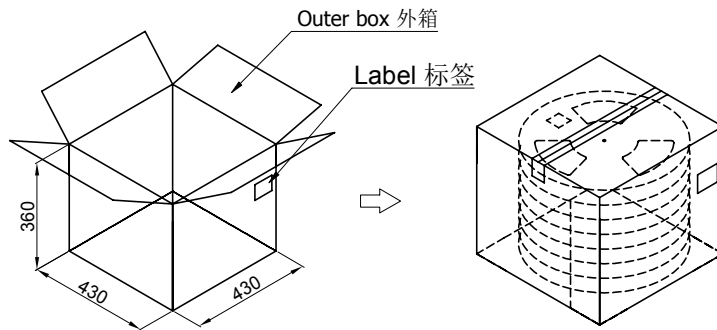
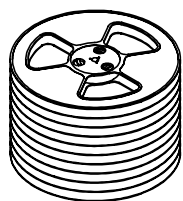
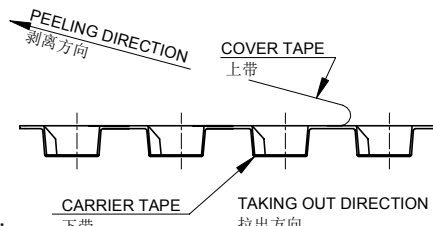

Note:

- Carrier Camber Is Within 1mm In 100mm ; 带长100mm内容许弯曲度1mm
- 10 Sprocket Hole Pitch Cumulative Tolerance±0.2MM ; 圆孔十个孔距离累计允许公差为±0.2mm
- Material for PS ; 材质为PS材质
- Thickness=0.30±0.05 ; 材料厚度为0.30±0.05mm
- Carton material纸箱材质:K=K; Carton Thickness纸箱厚度: 6~7mm

Pin No.	W	S	F	T	G	REEL /PCS	CARTON /R	CARTON /PCS
M1254WRS-02	16	/	7.50	20.50	16.40	2000	16R	32000
M1254WRS-03								
M1254WRS-04	24	/	11.50	28.50	24.40	2000	12R	24000
M1254WRS-05								
M1254WRS-06								
M1254WRS-07								
M1254WRS-08								
M1254WRS-09	32	28.40	14.20	36.50	32.40	2000	9R	18000
M1254WRS-10								
M1254WRS-11								
M1254WRS-12								
M1254WRS-13								
M1254WRS-14								
M1254WRS-15								
M1254WRS-16	44	40.40	20.20	48.50	44.40	2000	7R	14000
M1254WRS-17								
M1254WRS-18								
M1254WRS-19								
M1254WRS-20								

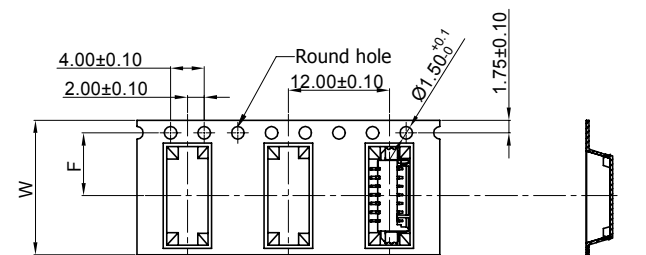

WIDTH=16~24mm

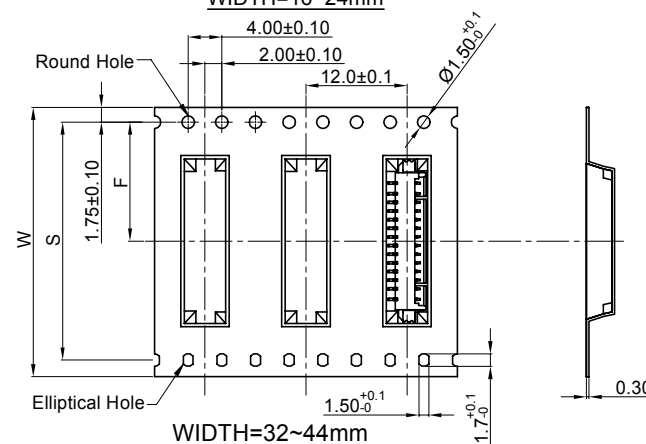

东莞市翰皓精密电子有限公司

DONGGUAN HANHAO PRECISION ELECTRONIC CO.,LTD

料号: M1254WRS-XX

名称: 1.25mm SMT 90° Packing

核准 审查 制作 日期
责能桂 / 唐华民 2017/07/24

单位 比例 页次 版本 编号
mm 1:1 1/1 B A-007

一般公差					
.X ±0.35					
.XX ±0.25					
.XXX ±0.15					
X° ±0.2°					
视角					
2020/03/26	B	EN20200326001	更新图框	秦胜钦	责能桂
日期	版次	变更编号	变更内容说明	变更人	核准