

东莞市翰皓精密电子有限公司

DONGGUAN HANHAO PRECISION ELECTRONIC CO.,LTD

| | | |
|--|--------------|------------|
| Product Specification [产品规格书]: | Document No | PS-1271-01 |
| Subject [主题]: 1.27mm Pitch 1271 Series Connector Specification | Date Issued | 2017/07/30 |
| | Date Revised | 2020/08/06 |
| | Version | C |

This specification is referred to the 1.27mm series wire to board connector

索引【INDEX】

1. 适用范围 【Scope】
2. 规格与料号 【Spec and Part number】
3. 材质与表面处理 【Disposal of Material and surface】
4. 额定等级 【Ratings and applicable wires】
5. 性能 【 Performance 】
 - 5-1. 电气的性能 【Electrical Performance.】
 - 5-2. 机械的性能 【Mechanical Performance】
 - 5-3. 环境性能及其它 【Environmental Performance and Others】

东莞市翰皓精密电子有限公司

DONGGUAN HANHAO PRECISION ELECTRONIC CO.,LTD

| | | |
|--|--------------|------------|
| Product Specification [产品规格书]: | Document No | PS-1271-01 |
| Subject [主题]: 1.27mm Pitch 1271 Series Connector Specification | Date Issued | 2017/07/30 |
| | Date Revised | 2020/08/06 |
| | Version | C |

【1.适用范围 Scope】

此种规格包括 1.27mm Pitch 1271 Series 排针排母连接器规格说明

This Specification Covers the 1.27mm Pitch 1271 Series PIN Header & Female Header Connector Specification.

【2.规格与料号 Spec and Part number】

| 规格内容 Specification | 产品料号 Production No. |
|-----------------------|--|
| 胶壳/Housing | 1271H-2*XX |
| 针座/Wafer | 1271W-2*XX 1271WR-2*XX 1271WS-2*XX |

【3.材质与表面处理 Disposal of Material and surface】

| 规格内容 Specification | 材质 Materials | 表面处理 Disposal of Surface |
|-----------------------|--------------------------------------|---|
| 胶壳/Housing | 端子 磷铜/Phosphor Bronze 黄铜/Brass | Gold Plated Nickel: Over 30 μ " or 50 μ " |
| | 塑胶 PBT or High Temp Plastic | UL 94V-0 |
| 针座/Wafer | Base PBT/High Temp Plastic | UL 94V-0 |
| | PIN 黄铜/Brass | Gold Plated Nickel: Over 30 μ " or 50 μ " |

(上述参数请以工程图为准/Please Refer to the Project drawing for the above Specification)

【4. 额定等级 Ratings and applicable wires】

| 项目【Item】 | 规格【Standard】 | |
|-------------------------------------|---|---------|
| 额定电压 Rated Voltage (Max.) | 250V | [AC/DC] |
| 额定电流 Rated Current (Max.) | 1A | |
| 使用温度范围 Ambient temperature Range | -40 $^{\circ}$ C ~+105 $^{\circ}$ C | |
| 适用线径 Applicable wire insulation O.D | UL2678 AWG 30# Insulation O.D. 0.60mm(Max.) | |

【*升温时含端子.Including terminal temperature rise.】

东莞市翰皓精密电子有限公司

DONGGUAN HANHAO PRECISION ELECTRONIC CO.,LTD

| | | |
|--|--------------|------------|
| Product Specification [产品规格书]: | Document No | PS-1271-01 |
| | Date Issued | 2017/07/30 |
| | Date Revised | 2020/08/06 |
| | Version | C |
| Subject [主题]: 1.27mm Pitch 1271 Series Connector Specification | | |
| | | |
| | | |
| | | |

【5.性能 PERFORMANCE】

5-1. 电气的性能 Electrical Performance.

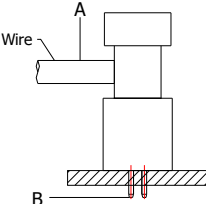
| 项目 【Item】 | 条件 【Test Condition】 | 规格 【Requirement】 |
|--|---|---|
| 5-1-1 接触阻抗 Contact Resistance | <p>公母配合,开放电压 20mV 以下,电流 10mA 检测连接器 A~B 区. Mate connectors, measure by dry circuit, 20mV MAX, 10mA. (Based upon EIA-364-06A).</p>  | <p>Initial: 20 milliohms Max. After Test: 40 milliohms Max.</p> |
| 5-1-2 绝缘阻抗 Insulation Resistance | <p>公母配合,在相邻端子,端子与地片之间,使用 500V 的直流电,检测连接器. Mate connectors, apply 500V DC between adjacent terminal or ground. (Based upon EIA-364-21B / MIL-STD-202 Method 302 Cond.B)</p> | 500 Megohms Min. |
| 5-1-3 耐电压 Dielectric Strength | <p>公母配合,在相邻端子,端子与地片之间,使用 500V 的交流电 1 分钟,检测连接器. Mate connectors, apply 500V AC for 1 minute between adjacent terminal or ground. (Based upon EIA-364-20A / MIL-STD-202 Method 301)</p> | <p>不出现中断等情况 No Breakdown and Flashover</p> |

| | | |
|---------------------------------------|--|------------|
| Product Specification [产品规格书]: | Document No | PS-1271-01 |
| | Date Issued | 2017/07/30 |
| | Date Revised | 2020/08/06 |
| | Version | C |
| Subject [主题]: | 1.27mm Pitch 1271 Series Connector Specification | |

5-2. 机械的性能 Mechanical Performance.

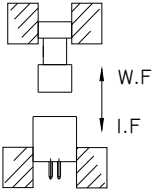
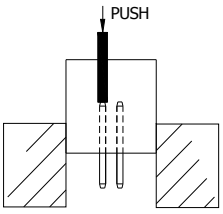
| 项目 【Item】 | 条 件 【Test Condition】 | 规 格 【Requirement】 |
|---|---|---|
| 5-2-1 插拔力 Insertion & Retention Force | <p>以每分钟 $25.4 \pm 3\text{mm}$ 的速率插入和拔出。 Insert and withdraw Connectors at the speed rate of $25.4 \pm 3\text{mm/minute}$.</p>  | <p>Mating Force: 0.3kgf/ Max./Per PIN Unmating Force: 0.03 Kgf/ Min Per PIN</p> |
| 5-2-2 Pin 针保持力 Pin Retention Force | <p>以每分 $25.4 \pm 3\text{mm}$ 的速率,将 PIN 针从 Wafer 内轴向拔出的力量。 Apply axial push force at the speed rate of $25.4 \pm 3\text{mm/minute}$.</p>  | <p>2.94N {0.3kgf} min.</p> |

5-3. 环境性能及其它 Environmental Performance and Others.

| 项目 【Item】 | 条 件 【Test Condition】 | 规 格 【Requirement】 | |
|---|---|-------------------------------|----------------------|
| 5-3-1 重复插拔 Repeated Insertion/ Withdrawal | <p>以每分钟不超过 10 次的速率,将公母插拔 30 次。 When mated up to 30 cycles repeatedly by the rate of 10 cycles per minute.</p> | 接触阻抗 Contact Resistance | 40 milliohms Max. |
| 5-3-2 温升测试 Temperature Rise | <p>公母对插后,在通过额定电流下,所测定的温度。 Carrying rated current load. (UL 1977)</p> | 温升测试 Temperature rise | 30°C Max. |

东莞市翰皓精密电子有限公司

DONGGUAN HANHAO PRECISION ELECTRONIC CO., LTD

| | | |
|--|--------------|------------|
| Product Specification [产品规格书]: | Document No | PS-1271-01 |
| | Date Issued | 2017/07/30 |
| | Date Revised | 2020/08/06 |
| | Version | C |
| Subject [主题]: 1.27mm Pitch 1271 Series Connector Specification | | |

| 项目 【Item】 | | 条 件 【Test Condition】 | 规 格 【Requirement】 | |
|--------------|------------------------|---|-------------------------------|------------------------|
| 5-3-3 | 耐振动性 Vibration | 振幅: 1.5mm P-P 时间: 10~55~10 HZ in 1 minute 持续时间: 每轴向 2 小时 Amplitude: 1.5mm P-P Sweep time: 10~55~10 HZ in 1 minute Duration: 2 hours in each X.Y.Z axials. (Based upon EIA-364-28B/MIL-STD-202 Method 213B Cond.A) | 外观 Appearance | 无异状 No Damage |
| | | | 接触阻抗 Contact Resistance | 40 milliohms Max. |
| | | | 瞬断 Discontinuity | 1 micro-second Max. |
| 5-3-4 | 耐冲击性 Shock | 在 X.Y.Z 上 6 个方向上,以 490m/s ² (50g 的 力量)冲击下各 3 回 .490m/s ² {50G}, 3 strokes in each X.Y.Z. axes. (Based upon EIA-364-27B/MIL-STD-202 Method 213B Cond.A) | 外观 Appearance | 无异状 No Damage |
| | | | 接触阻抗 Contact Resistance | 40 milliohms Max. |
| | | | 瞬断 Discontinuity | 1 micro-second Max. |
| 5-3-5 | 耐热性 Heat Resistance | 105±2°C, 96 hours. (Based upon MIL-STD-202 Method 108A Cond.A) | 外观 Appearance | 无异状 No Damage |
| | | | 接触阻抗 Contact Resistance | 30 milliohms Max. |
| 5-3-6 | 耐寒性 Cold Resistance | -40±5°C, 96 hours. (Based upon EIA-364-105) | 外观 Appearance | 无异状 No Damage |
| | | | 接触阻抗 Contact Resistance | 40 milliohms Max. |
| 5-3-7 | 耐湿性 Humidity | 温度: 40±2°C 湿度: 90~95%(RH) 持续时间: 96 hours Temperature: 40±2°C Relative Humidity: 90~95% Duration: 96 hours (Based upon EIA-364-31A/MIL-STD-202 Method 103B Cond.B) | 外观 Appearance | 无异状 No Damage |
| | | | 接触阻抗 Contact Resistance | 40 milliohms Max. |
| | | | 耐电压 Dielectric Strength | Must meet 5-1-3 |
| | | | 绝缘阻抗 Insulation Resistance | 500 Megohms Min. |

东莞市翰皓精密电子有限公司

DONGGUAN HANHAO PRECISION ELECTRONIC CO., LTD

| | | |
|--|--------------|------------|
| Product Specification [产品规格书]: | Document No | PS-1271-01 |
| | Date Issued | 2017/07/30 |
| | Date Revised | 2020/08/06 |
| | Version | C |
| Subject [主题]: 1.27mm Pitch 1271 Series Connector Specification | | |
| | | |
| | | |
| | | |

| 项目 【Item】 | | 条 件 【Test Condition】 | 规 格 【Requirement】 | |
|--------------|--------------------------------|---|-------------------------------|---|
| 5-3-8 | 温度变化 Temperature Cycling | 从-40℃持续30分钟升至+105℃持续30分钟, 循环5次. 5 cycles of: a) -40℃ 30 minutes. b) +105℃ 30 minutes. (Based upon EIA-364-32B) | 外观 Appearance | 无异状 No Damage |
| | | | 接触阻抗 Contact Resistance | 40 milliohms Max. |
| 5-3-9 | 盐水喷雾 Salt Spray | 在温度 35±2℃, 盐水浓度 5±1% 下, 盐水喷雾 48±1 小时. 48±1 hours exposure to a salt spray from the 5±1% solution at 35±2℃. (Based upon EIA-364-26B/MIL-STD-202 Method 101D Cond.B). | 外观 Appearance | 无异状 No Damage |
| | | | 接触阻抗 Contact Resistance | 40 milliohms Max. |
| 5-3-10 | 焊锡附着性 Solder- ability | 焊接时间: 3~5 秒. 焊接温度: 245±5℃. Soldering Time: 3~5second. Solder Temperature: 245±5℃. (Based upon EIA-364-52) | Solder Wetting | 浸渍面积需 95% 以上 95% of immersed area must show no voids, pin holes. |
| 5-3-11 | 焊锡耐热性 Solder- Resistance | 焊接时间: 3~5 秒. 焊接温度: 255+5/-5℃. Soldering time: 3~5 sec solder. Temperature: 255+5/-5℃. (Based upon EIA-364-56A) | 外观 Appearance | 无异状 No Damage |